

Montageanleitung

Seil-Endterminal Selbstverpressung

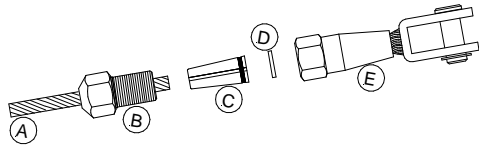

Ausschließlich zur Verwendung mit ST Quadrat s.a. LUX-top® FSE Edelstahlführungsseilen



Die Verschraubung besteht aus einem Konusteil (B), Drei Seilkeilen mit O-Ring (C), einer Messingscheibe (D) Und einem Anschlussstück (E).

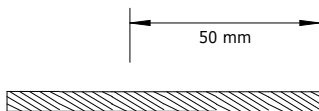

WICHTIG: Das Seilende (A) (ca. 50 mm) muss absolut öl- und fettfrei sein! Nötigenfalls entfetten.

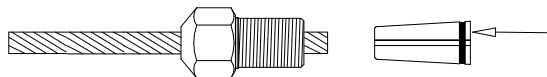

Konusteil (B) auf das Seil (A) aufschieben und die Seilkeile (C) ausrichten.

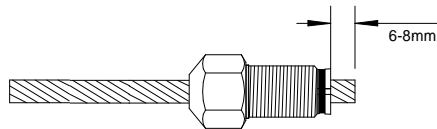

Konusteil (B) leicht nach vorne drücken, so dass sich die Seilkeile (C) verklemmen. Das Seil muss **6-8 mm vorstehen !**

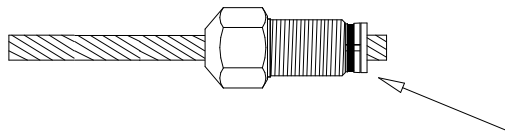

Messingscheibe aufschieben!

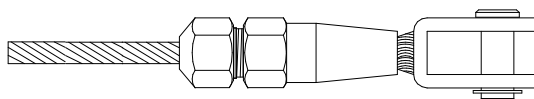

Teile mit Anschlussstück (E) zusammenschrauben und **von Hand festziehen!**

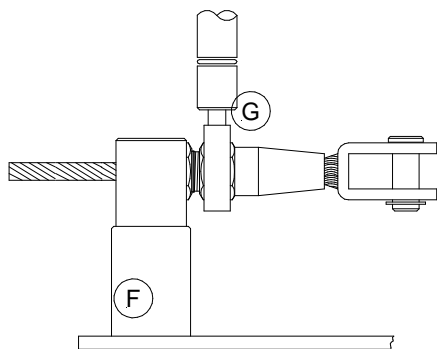

Mit der Montagehilfe (F) und einem Drehmomentschlüssel mit offenem Ringschlüssel (G) die Verschraubung mit dem erforderliche **Drehmoment von 50 Nm** festziehen!

Die korrekte Montage hat der Anwender selbstverantwortlich zu prüfen!

Installation Instructions

Rope terminal, self-splicing



Exclusively for use with ST Quadrats s.a. LUX-top® FSE stainless steel guide ropes

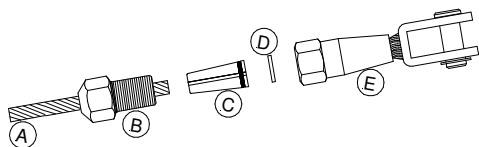

The screw connection of a cone part (B), three rope wedges with O-ring (C), one brass disc (D) and one connecting part (E).

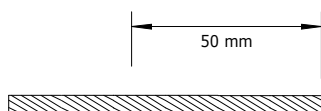

IMPORTANT: The end of the rope (A) (approx. 50 mm) must be absolutely free from oil and grease! Degrease, if required.

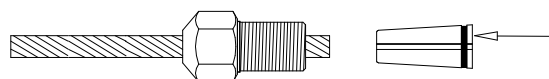

Slide cone part (B) on the rope (A) and align the rope wedges (C).

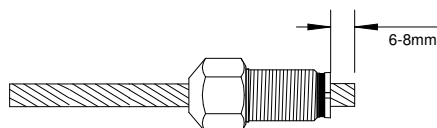

Press cone part (B) slightly forward so that the rope wedges (C) will seize. The rope must **protrude 6-8 mm!**

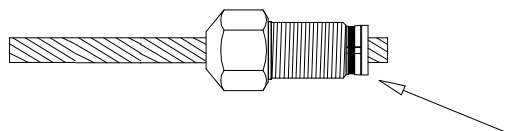

Slide on the brass disc!

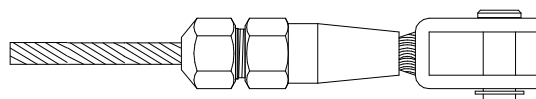

Screw together the parts with connecting part (E) and **tighten by hand!**

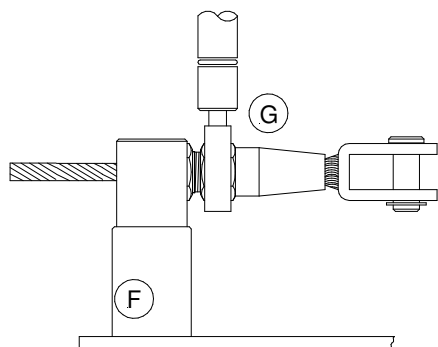

Tighten the screw connection with the fit-up aid (F) and a torque wrench with open ring spanner (G) to the required **torque of 50 Nm!**

The user shall check correct installation in his own responsibility!

Instructions de montage

Lux-top® ridoir de câble à sertir manuellement



Exclusivement destiné à un emploi avec les produits de ST Quadrat notamment les câbles de guidage en acier inox LUX-top® FSE

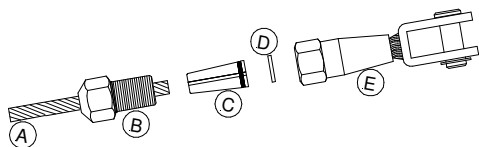

Le vissage est composé d'un cône (B), de trois coins de câble à joint torique (C), d'une rondelle en laiton (D) et d'un raccord (E).

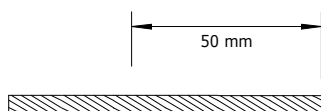

IMPORTANT : l'extrémité du câble (A) (env. 50 mm) doit être absolument exempte d'huile et de graisse ! Dégraissez-la au besoin.

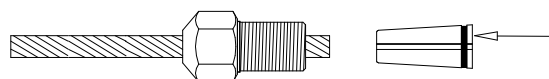

Placez le cône (B) sur le câble (A) et alignez les coins de câble (C).

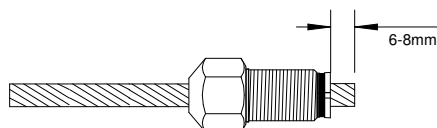

Poussez le cône (B) légèrement en avant de manière à ce que les coins de câble (C) se bloquent. Le câble doit **dépasser de 6 à 8 mm !**

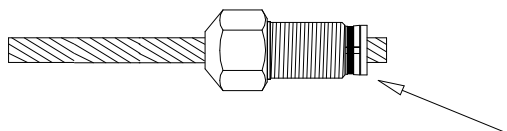

Mettez la rondelle en laiton en place !

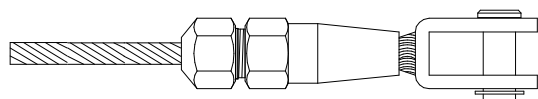

Vissez les pièces entre elles à l'aide du raccord (E) et **serrez à bloc à la main !**

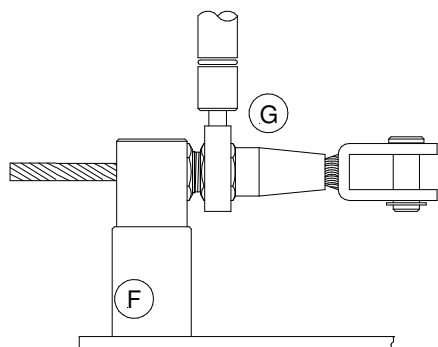

Servez-vous ensuite de la pièce d'aide au montage (F) et d'une clé dynamométrique à clé polygonale ouverte (G) pour serrer le vissage à bloc en appliquant le **couple de rotation requis de 50 Nm !**

Il va de soi que l'utilisateur est tenu de vérifier le montage correct de son propre chef !

Montagehandleiding

Kabeleindterminal zelfmontage



Uitsluitend voor het gebruik met ST Quadrats s.a. LUX-top® FSE roestvrij stalen leikabels

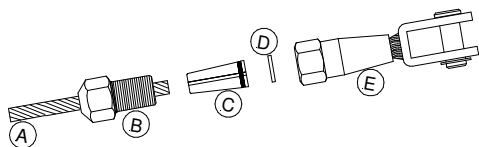

De schroefverbinding bestaat uit een conusdeel (B), drie kabelklemmen met O-ring (C), een messingschijf (D) en een aansluitingsgedeelte (E).

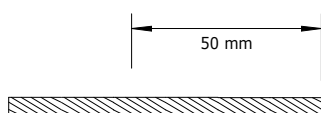

BELANGRIJK: Het kabeleind (A) (ca. 50 mm) moet absoluut olie- en vetvrij zijn! Desnoeds ontvetten.

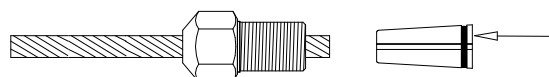

Conusdeel (B) op de kabel (A) schuiven en de kabelklemmen (C) uitlijnen.

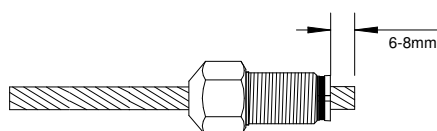

Conusdeel (B) lichtjes voorwaarts duwen zodat de kabelklemmen (C) vastzitten. De kabel moet **6-8 mm uitsteken!**

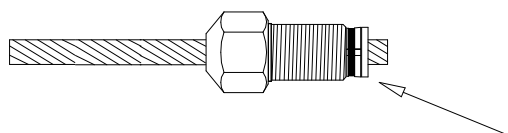

Messingschijf erop schuiven!

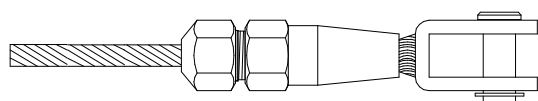

Onderdelen met aansluitingsgedeelte (E) aaneenschroeven en **met de hand vast aandraaien!**

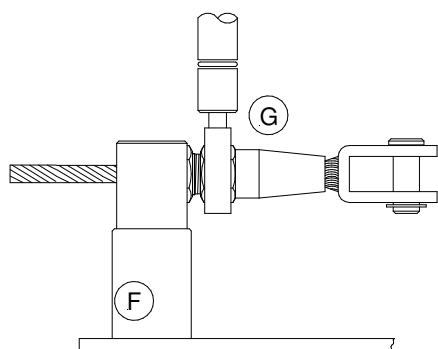

Met het montagehulpmiddel (F) en een momentbegrenzende sleutel met open ringsleutel (G) de schroefverbinding met het ingestelde **draaimoment van 50 Nm** vast aantrekken!

De correcte montage dient de gebruiker op eigen verantwoordelijkheid na te kijken!

Instrucciones de montaje

Terminal de horquilla para autoprensado



Para usar exclusivamente en la línea de vida LUX-top® FSE 2003 de ST Quadrat s.a.

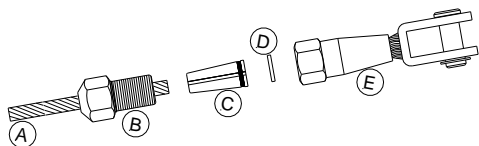

El racor se compone de una parte cónica (B), tres cuñas con junta tórica (C), una arandela de latón (D) y una pieza de conexión (E).

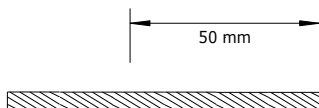

IMPORTANTE: la extremidad del cable (A) (aprox. 50 mm) debe estar completamente limpia, sin aceite o grasa! Limpiar si es necesario.

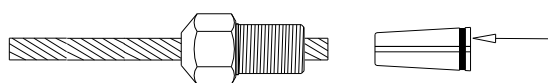

Pasar el cable (A) por la parte cónica (B) e insertar las cuñas (C).

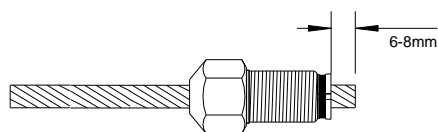

Tirar suavemente de la parte cónica (B) hacia afuera, de manera que las cuñas (C) queden bloqueadas.
¡El cable debe **sobresalir entre 6-8 mm!**

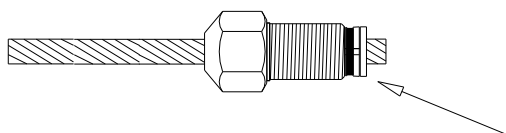

¡Introducir la arandela de latón!

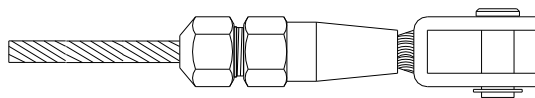

¡Montar con la pieza de conexión (E) enroscándolo y **apretar a mano!**

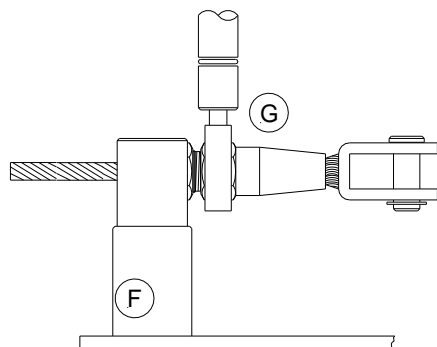

¡Con la ayuda de la placa para montaje (F) y la llave dinamométrica (G), fijar con el **par de apriete de 50 Nm** requerido!

¡El usuario tiene la responsabilidad de comprobar que el montaje es correcto!